

IONIQ Plug-in

Emergency Response Guide



Series 1 (2017 ~ 2019)



Series 2 (2019 ~ ~)

HYUNDAI HELP LINE
0800 HYUNDAI (498 632)

⚠ WARNING

- If severe damage causes high-voltage components to become exposed, emergency responders should take appropriate precautions and wear appropriate insulated personal protective equipment.
- Do not attempt to remove the safety plug while standing in the water.
- Never cut or disconnect the high voltage orange cabling and connectors without first disabling the system by removing the safety plug.
- Exposed cables or wires may be visible inside or outside the vehicle. Never touch the wires, cables, connectors, or any electric components before disabling the system, to prevent injury or death due to electrical shock.

Failure to follow any of these instructions may result in serious injury or death by electrocution.

- Do not cut through any component of the Airbag (SRS) system (Supplementary Restraint System)
- SRS components may remain powered and active for up to 3 minutes after the 12V electrical system is shut off or disabled.

Disconnect the battery negative cable and wait for at least 3 minutes before beginning work.

Failure to follow any of these instructions may result in serious injury or death from accidental deployment of the airbag system.

This manual includes information titled as DANGER, WARNING, CAUTION & NOTICE.

These titles indicate the following:

DANGER

DANGER indicates a hazardous situation which, if not avoided, will result in death or serious injury.

WARNING

WARNING indicates a hazardous situation which, if not avoided, could result in death or serious injury.

CAUTION

CAUTION indicates a hazardous situation which, if not avoided, could result in minor or moderate injury.

NOTICE

NOTICE indicates a situation which, if not avoided, could result in vehicle damage.

WARNING

- If severe damage causes high-voltage components to become exposed, emergency responders should take appropriate precautions and wear appropriate insulated personal protective equipment.
- Do not attempt to remove the safety plug while standing in the water.
- Never cut or disconnect the high voltage orange cabling and connectors without first disabling the system by removing the safety plug.
- Exposed cables or wires may be visible inside or outside the vehicle. Never touch the wires, cables, connectors, or any electric components before disabling the system, to prevent injury or death due to electrical shock.

Failure to follow any of these instructions may result in serious injury or death by electrocution.

- Do not cut through any component of the Airbag (SRS) system (Supplementary Restraint System)
- SRS components may remain powered and active for up to 3 minutes after the 12V electrical system is shut off or disabled. Disconnect the battery negative cable and wait for at least 3 minutes before beginning work.

Failure to follow any of these instructions may result in serious injury or death from accidental deployment of the airbag system.

This manual includes information titled as DANGER, WARNING, CAUTION & NOTICE.

These titles indicate the following:

DANGER

DANGER indicates a hazardous situation which, if not avoided, will result in death or serious injury.

WARNING

WARNING indicates a hazardous situation which, if not avoided, could result in death or serious injury.

CAUTION

CAUTION indicates a hazardous situation which, if not avoided, could result in minor or moderate injury.

NOTICE

NOTICE indicates a situation which, if not avoided, could result in vehicle damage.

WARNING

- If severe damage causes high-voltage components to become exposed, emergency responders should take appropriate precautions and wear appropriate insulated personal protective equipment.
- Do not attempt to remove the safety plug while standing in the water.
- Never cut or disconnect the high voltage orange cabling and connectors without first disabling the system by removing the safety plug.
- Exposed cables or wires may be visible inside or outside the vehicle. Never touch the wires, cables, connectors, or any electric components before disabling the system, to prevent injury or death due to electrical shock.

Failure to follow any of these instructions may result in serious injury or death by electrocution.

- Do not cut through any component of the Airbag (SRS) system (Supplementary Restraint System)
- SRS components may remain powered and active for up to 3 minutes after the 12V electrical system is shut off or disabled. Disconnect the battery negative cable and wait for at least 3 minutes before beginning work.

Failure to follow any of these instructions may result in serious injury or death from accidental deployment of the airbag system.

Important Safety Information

Introduction	4
IONIQ Plug-in Identification	5
- General Vehicle Description	5
- Identifying a Hyundai electric vehicle.....	5
IONIQ Plug-in Main Systems	11
- Key Specifications	11
- Vehicle Components Location	12
- Vehicle Components	13
- Airbag system (SRS : Supplemental Restraint System)	18
Emergency Procedures	20
- Initial response: Identify, Immobilize and Disable	20
- Extraction Operations	25
- Submersion	27
- Vehicle Fire	28
- High-Voltage Battery Damage and Fluid Leaks	29
Roadside Assistance	
- Towing	30
- To Jump Start the Car	31

Document Purpose

The purpose of this document is to familiarise emergency responders and the towing/roadside assistance industry with the proper methods to handle the Hyundai IONIQ Plug-in Hybrid in an emergency situation. This guide offers a basic overview of key vehicle systems and provides instructions for dealing with the different types of situations encountered by emergency responders. The emergency response procedures for this vehicle are somewhat similar to a conventional vehicle with additional information provided on dealing with the high-voltage electrical system.

Vehicle Description

As with other Plug-in Hybrids, the Hyundai IONIQ Plug-in Hybrid uses a conventional gasoline powered internal combustion engine paired with a high-voltage electric motor to propel the vehicle. The high-voltage battery is recharged by an external power source such as a charging station through charging port. It is also recharged while the vehicle is being driven. This is accomplished through the use of a generator that produces electricity during driving and braking.



General Vehicle Description

The Hyundai IONIQ five-door hatchback using a chassis developed for eco-friendly vehicles has hybrid, Plug-in Hybrid and EV models. The Hyundai IONIQ Plug-in Hybrid looks very similar to the EV model with a few notable exceptions. The safest method is to assume that any IONIQ you respond to is equipped the high voltage system because the IONIQ is exclusive model for eco-friendly vehicle. Using the information provided in this section, responders will be able to differentiate between the three.

Identifying a Hyundai Plug-in Hybrid Vehicle

Plug-in Hybrid badge on Boot and Blue Drive badge on side of Vehicle.

The Hyundai IONIQ Plug-in Hybrid can be easily identified by the 'plug-in' and the 'IONIQ' badge located on the boot lid and the 'BLUE-DRIVE' badge on the left side of the vehicle.

⚠ DANGER Electrocutation Risk

Badging can become hidden after a crash due to damage to the vehicle. Always be sure to utilize additional methods if identification before determining there is no badge present.



VIN Number

Vehicle Identification Number (VIN) identifies the Plug-in Hybrid Vehicle with a “C” displayed in the 8th position, as shown in the below drawing. The VIN is punched on the floor under the passenger seat. The letter C in the 8th character of the VIN indicates that it is a Plug-in Hybrid with 1.6 Petrol engine.

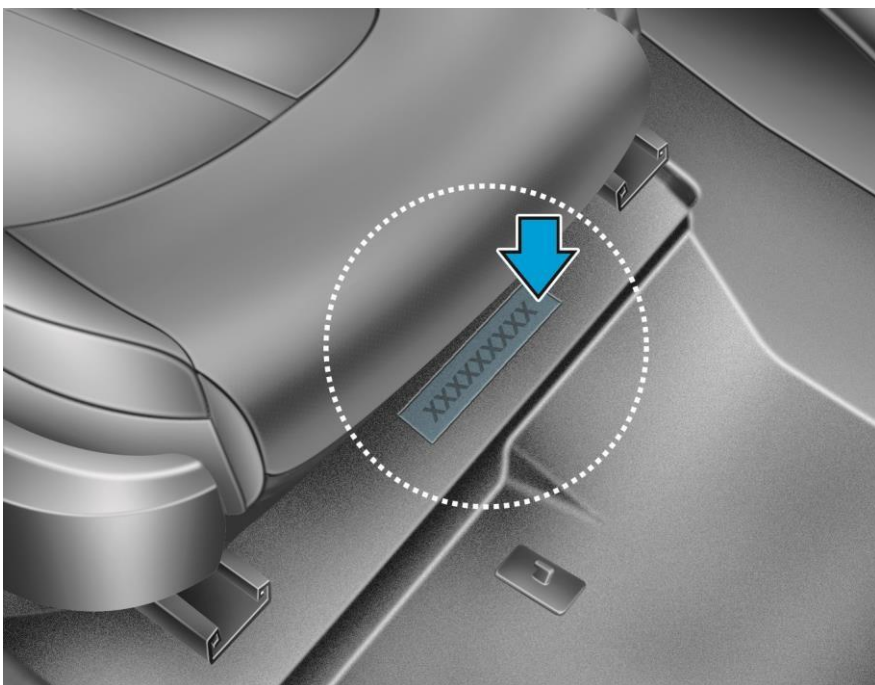
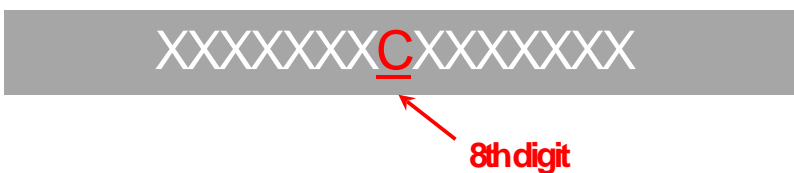

Engine Compartment

The IONIQ Plug-in Hybrid has a plastic air cleaner assembly with “Plug-in HYBRID” clearly shown on it.



Additionally, there are orange coloured high-voltage electrical cables in the engine compartment.



Vehicle Underside

An orange coloured cable covered by the under cover is also visible on the underside of the vehicle. This cable runs along the driver side from the rear of the vehicle to the engine compartment.



Charging Port

The Charging Port is located on the front fender covered by the charging port cap and it has one port for AC normal charging.

How to open the charging port.

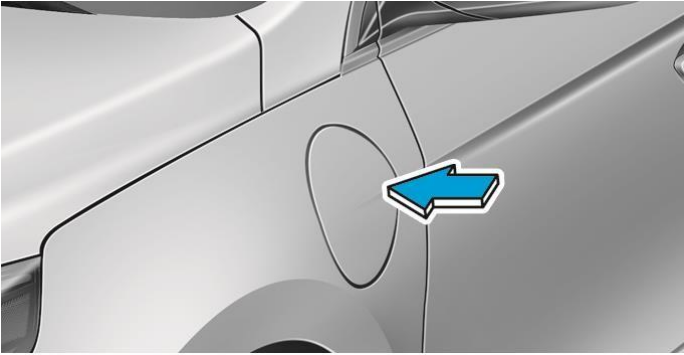

1. Depress the brake pedal and apply the parking brake.

2. Turn OFF all switches, move the shift lever to P (Park), and turn OFF the vehicle.

3. Open the charging door by pressing it. (The charging door opens only when the vehicle doors are unlocked.)

4. Open the charging inlet cover.

Unlock Charging Connector in Emergency

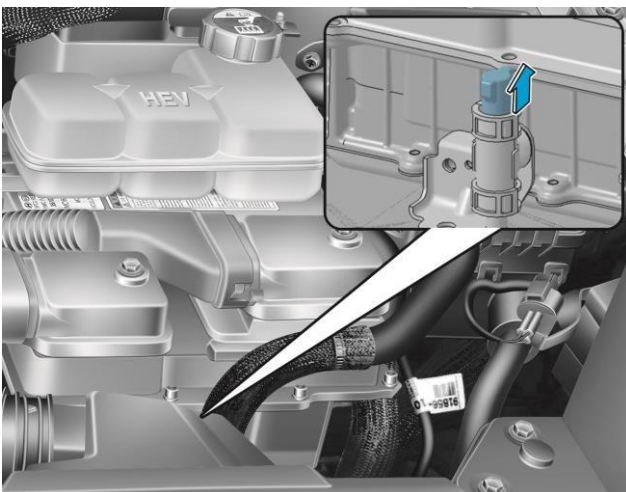

If the charging door does not open or the charging cable is not disconnected, open the hood and pull the emergency cable lightly as shown left. The charging connector will then disconnect.

Plug-in Hybrid Vehicle Cluster Instrument Panel

The Plug-in Hybrid Vehicle Instrument Cluster Panel displays the Plug-in Hybrid vehicle specific features that identify the IONIQ as a Plug-in Hybrid vehicle.

- 1 Regeneration brake/ECO/power gauge.
- 2 SOC (high voltage battery) Indicator indicates the charge state of the high voltage battery.
- 3 EV mode indicator indicates the operation states of the motor according to the vehicle driving states. It is turned off when the vehicle stops.
- 4 Ready Light indicates the vehicle is ready for driving.
- 5 Charging Cable Connection Indicator illuminates in red when the charging cable is connected.
- 6 Plug-in hybrid mode indicator indicates the current mode.



A-Type



B-Type

Charge Status Indicator

The battery charge status indicator, visible from outside, at the centre of the crash-pad, is illuminated when the vehicle is charging.



Key Specifications

Item		Plug-in Hybrid
Engine	CC	1.6 L GDi Plug-in Hybrid Engine
Transmission	Type	6 Speed DCT
Fuel Tank	Capacity (ℓ)	45
Transmission	Type	6 Speed DCT
EV Motor	Type	Permanent Magnet Synchronous Motor
	Max. Output (kW)	44.5
	Max. Torque (Nm)	170
Inverter	Voltage	240 ~ 413 V
High Voltage Battery	Type	Lithium-ion Polymer
	Rated Voltage	360
	Capacity (Ah) / Energy (kWh)	24.7 / 8.89
	Number of Packs (Cell / Module)	4 Cells x 24 Modules (96 Cells Total)

Vehicle Components Location

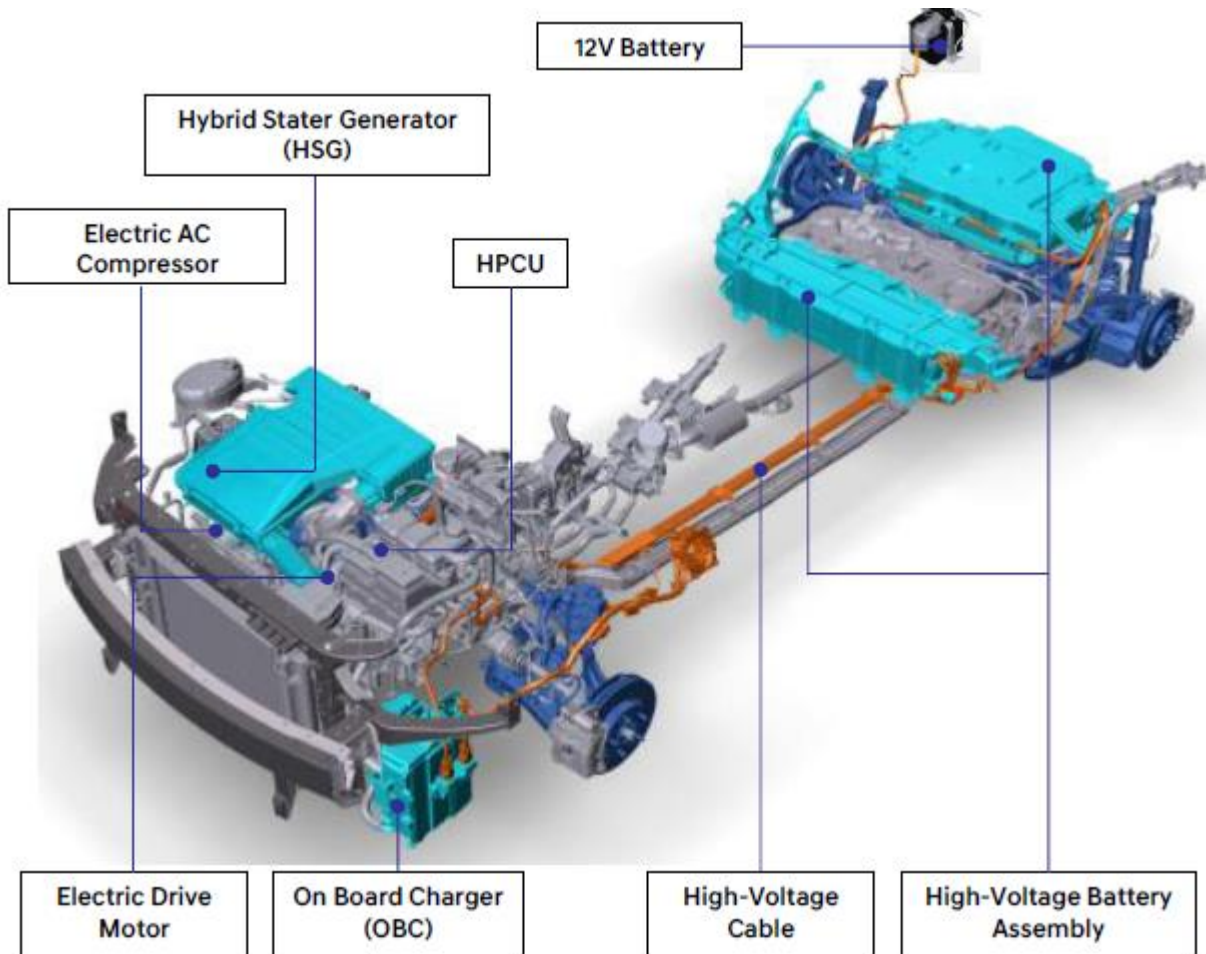

OBC	On-Board Charger : Battery charging equipment (AC → DC)
HPCU	Hybrid Power Control Unit (Inverter + LDC + HCU)
LDC	Low Power DC-DC Converter : Charge 12V supplementary battery
Inverter	DC → AC (from battery to motor) AC → DC (charge using regenerative braking)
Motor	When current flows through the coil. It generates a rotating magnetic field and generates motor torque.
High voltage battery	Supplies and stores electric energy to traction motor.

IONIQ Plug-in Hybrid Main Systems

WARNING

Electrocution Risk!

- Never cut or disconnect the high voltage orange cabling and connectors without first disabling the system by removing the safety plug.
- Exposed cables or wires may be visible inside or outside the vehicle. Never touch the wires, cables, connectors, or any electric components before disabling the system, to prevent injury or death due to electrical shock.

Failure to follow these instructions can lead to death by electrical shock.

Vehicle Components

12V Auxiliary Battery The 12V Auxiliary Battery is located in the right hand side of the boot and is accessed by removing a small cover. This battery powers all of the standard electronics like radio, air conditioner, etc. It also supplies current to the high-voltage system relays, which control the flow of high-voltage current.

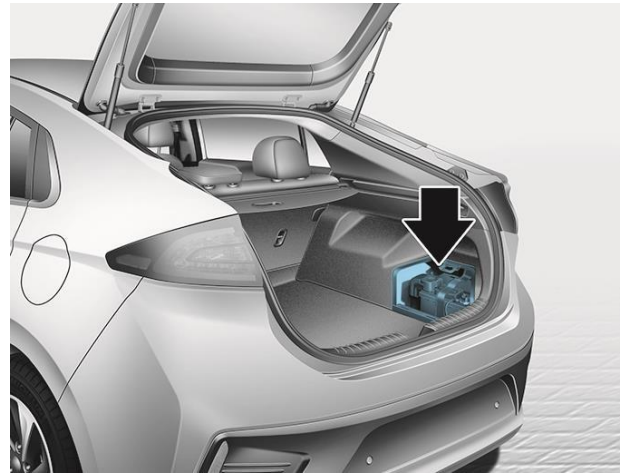

High-Voltage (HV) Battery

The Lithium-ion Polymer HV battery contains a gel electrolyte and is made up of 96 - 3.75V cells wired in series for a nominal voltage of 360V with 24.7 Ah of capacity. The battery is located below the rear seat and under the boot area.

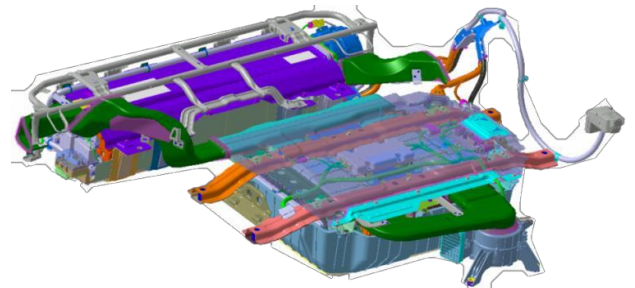

Air Conditioning Compressor

The Air Conditioning Compressor is mounted to the engine directly below the HSG. It is also powered by the high-voltage system, so its electrical connection via an orange HV cable is easily noticeable as well.



IONIQ Plug-in Hybrid Main Systems

WARNING

Electrocution Risk!

- Never cut or disconnect the high voltage orange cabling and connectors without first disabling the system by removing the safety plug.
- Exposed cables or wires may be visible inside or outside the vehicle. Never touch the wires, cables, connectors, or any electric components before disabling the system, to prevent injury or death due to electrical shock.

Failure to follow these instructions can lead to death by electrical shock.

Hybrid Power Control Unit

The Hybrid Power Control Unit (HPCU) assembly consists of three components : a Hybrid Control Unit (HCU), an Inverter (Motor Control Unit (MCU)) as well as a Low-voltage DC-DC Converter (LDC). The HPCU assembly contains capacitors which take about 5-10 minutes to discharge after the high-voltage system is shut down.

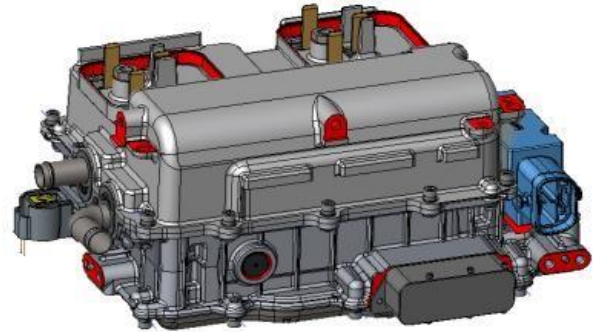

Electric Drive Motor

Mounted between the engine and transmission, the Electric Drive Motor is used for vehicle propulsion. During deceleration or braking, it acts as an alternator and charges the HV battery by converting the vehicle's kinetic energy into electrical energy.



Hybrid Starter Generator (HSG)

The HSG is mounted to the front of the engine near the intake manifold. It cranks the engine or starting and acts as a generator when the HV battery needs charging. As this is one of the major components of the HV system, its electrical connection is clearly visible via an orange HV cable.

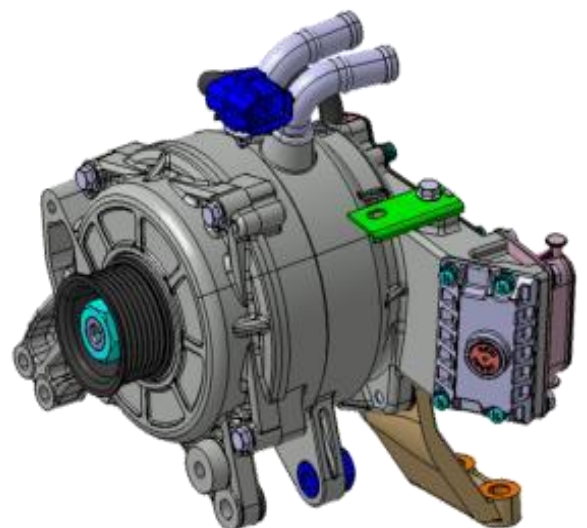

IONIQ Plug-in Hybrid Main Systems

WARNING

Electrocution Risk!

- Never cut or disconnect the high voltage orange cabling and connectors without first disabling the system by removing the safety plug.
- Exposed cables or wires may be visible inside or outside the vehicle. Never touch the wires, cables, connectors, or any electric components before disabling the system, to prevent injury or death due to electrical shock.

Failure to follow these instructions can lead to death by electrical shock.

On-Board Charger (OBC)

The OBC is the battery charging equipment that converts external AC to DC to charge the high voltage battery.

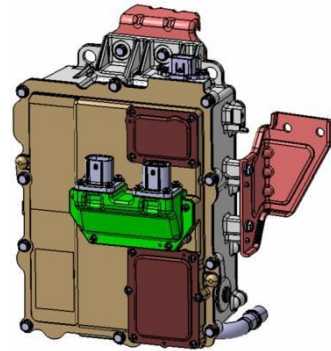

High-Voltage Cabling

The high-voltage cabling in the IONIQ Plug-in Hybrid is orange per the SAE standard. These cables run along the driver side from the rear of the vehicle where they connect to the HV battery up to the front of the vehicle where they connect to the Electric Drive Motor and other HV components.

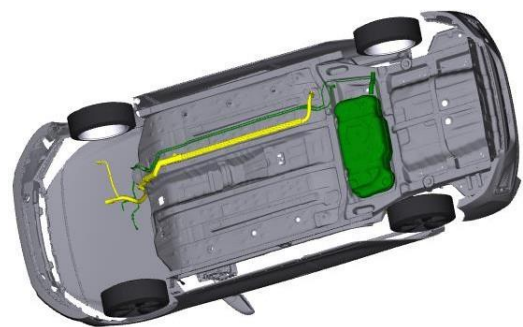

⚠️ WARNING Electrocutation Risk

- Never cut or disconnect the high voltage orange cabling and connectors without first disabling the system by removing the safety plug.
- Exposed cables or wires may be visible inside or outside the vehicle. Never touch the wires, cables, connectors, or any electric components before disabling the system, to prevent injury or death due to electrical shock.

Failure to follow these instructions can lead to death by electrical shock.

IONIQ Plug-in Hybrid Main Systems

WARNING

Electrocution Risk!

- Never cut or disconnect the high voltage orange cabling and connectors without first disabling the system by removing the safety plug.
- Exposed cables or wires may be visible inside or outside the vehicle. Never touch the wires, cables, connectors, or any electric components before disabling the system, to prevent injury or death due to electrical shock.

Failure to follow these instructions can lead to death by electrical shock.

Plug-in Hybrid System Operation

Operating Parameters The Plug-in Hybrid IONIQ has two modes of using charged electricity. One is Charge Depleting (CD) mode where the vehicle is propelled by the electric motor only until it depletes to the predefined level of high-voltage battery. The other one is Charge Sustaining (CS) mode where the vehicle is propelled by either the gasoline engine or the Electric Drive Motor, or a combination of both.

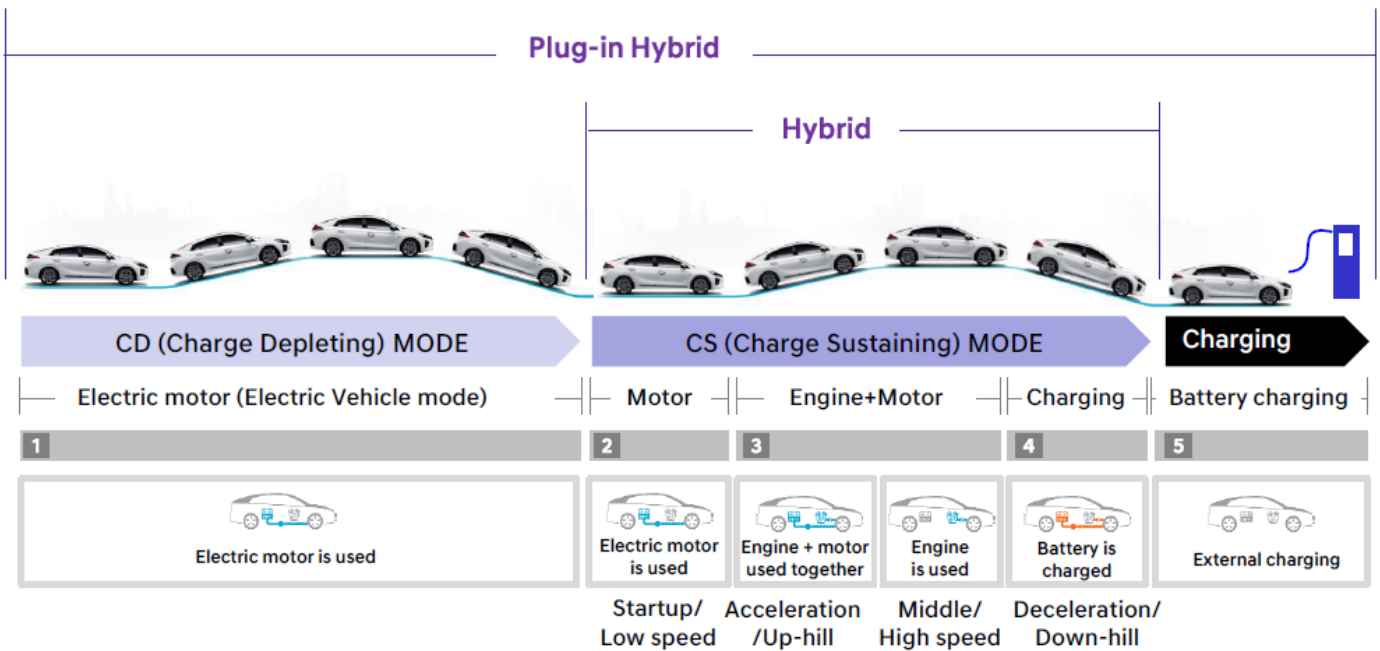

IONIQ Plug-in Hybrid Main Systems

WARNING

Electrocution Risk!

- Never cut or disconnect the high voltage orange cabling and connectors without first disabling the system by removing the safety plug.
- Exposed cables or wires may be visible inside or outside the vehicle. Never touch the wires, cables, connectors, or any electric components before disabling the system, to prevent injury or death due to electrical shock.

Failure to follow these instructions can lead to death by electrical shock.

High-Voltage Electrical Isolation

Unlike the 12V electrical system that is grounded to the vehicle's chassis, the IONIQ Plug-in Hybrid's high-voltage electrical system is designed to be isolated from the vehicle.

Regulation of High-Voltage Electrical Current

Current from the High-Voltage Battery is controlled by the Power Relay Assembly (PRA), which consists of Positive and Negative Main Relays, a Pre-charge Relay, Pre-charge Resistor, and the Battery Current Sensor. The PRA is located inside the High-Voltage Battery Pack Assembly and controls the high-voltage power circuit between the High-Voltage Battery and the Hybrid Power Control Unit.

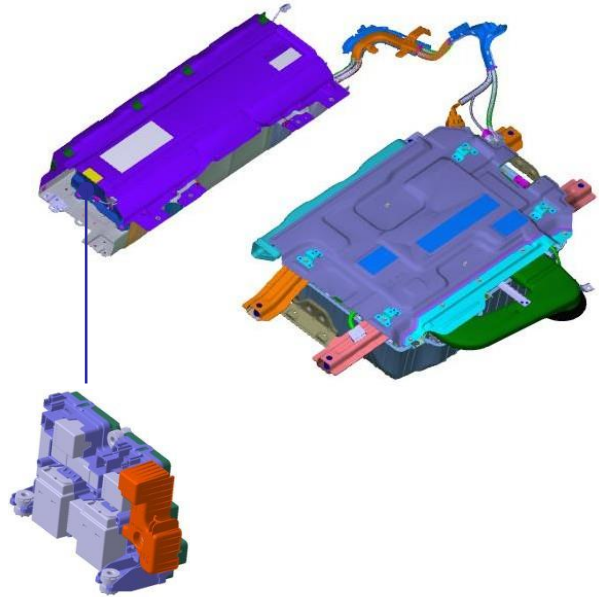

High-Voltage Safety System

There are multiple safety systems incorporated into the IONIQ Plug-in Hybrid. The system that protects the High-Voltage Electrical System is called the Battery Management System (BMS). The BMS is located inside the High-Voltage Battery assembly and measures several parameters to maintain the optimal performance of the High-Voltage Battery. It controls the battery cooling fan to ensure proper battery operation. In addition, if a system fault occurs, the BMS turns off the PRA to protect the system.

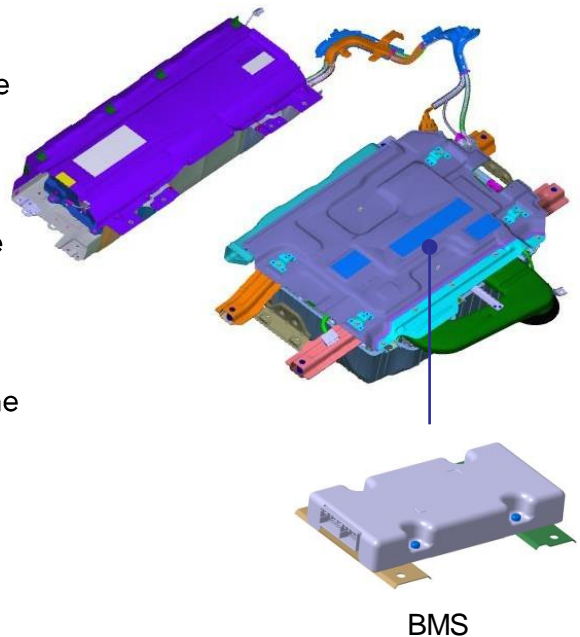

Airbag system (SRS : Supplemental Restraint System)

Airbag

Seven airbags are installed in the IONIQ Plug-in Hybrid as shown below. Before starting any emergency procedure, make sure the vehicle ignition is turned off, disconnect the negative cable from the 12V auxiliary battery to prevent accidental deployment of airbags.



* The actual air bags and seats in the vehicle may differ from the illustration

Number	Name	Location
1	Driver's front airbag	Driver side
2	Passenger's front airbag	Passenger side
3, 4	Side airbag	Driver / Passenger side
5, 6	Curtain airbag	Driver / Passenger side
7	Knee airbag	Driver side

Seat Belt Pretensioners

The IONIQ Plug-in Hybrid is equipped with driver's and front passenger's seat belts with pretensioners. When the seat belt pretensioners are activated in a collision, a loud noise may be heard and fine dust, which may appear to be smoke, may be visible in the passenger compartment. These are normal operating conditions and are not hazardous. The seat belt pretensioner assembly mechanisms may become hot during activation, and may need several minutes to cool after they have been activated.

Sensors and Control Module

The airbags and pretensioners are managed by the SRS Control Module, or SRSCM, which is located below the front of the centre console. In addition, there are four side impact sensors : two conventional accelerometer sensors in the B-pillars, and two pressure sensing sensors inside of the front door modules. Their locations are illustrated in the image below.

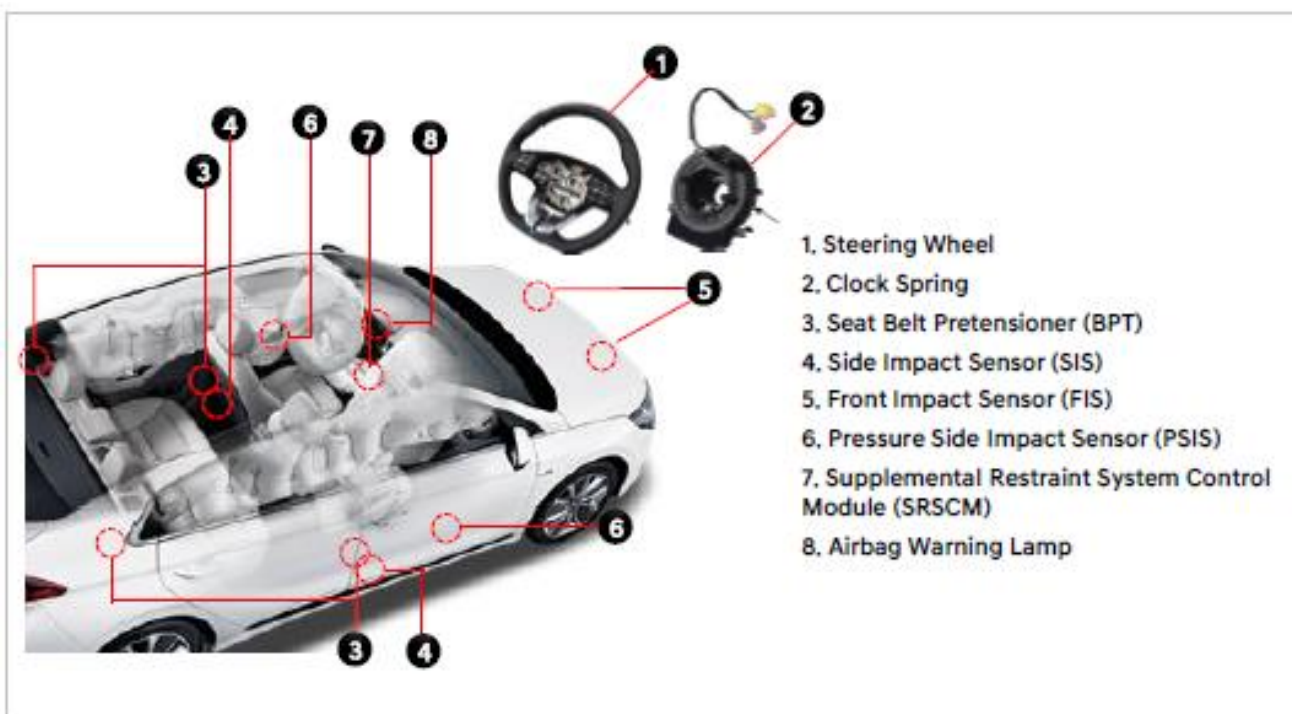

⚠ WARNING

- Do not cut through any component.
- SRS components may remain powered and active for up to 3 minutes after the 12V electrical system is shut off or disabled. Disconnect the battery negative cable and wait for at least 3 minutes before beginning work.

Failure to follow any of these instructions may result in serious injury or death from accidental deployment of the airbag system.

Initial Response:

The following procedures should be used whenever you are dealing with a IONIQ Plug-in Hybrid at an emergency scene. All other operations should be consistent with your department's standard operating procedures or guides. Plug-in Hybrid vehicles damaged by a crash may have compromised high voltage safety systems and present a potential high voltage electrical shock hazard. Exercise caution and wear appropriate personal protective equipment (PPE) safety gear, including high voltage safety gloves and boots. Remove all metallic jewellery, including watches and rings.

Identify

When dealing with a IONIQ at the scene of an accident, emergency responders should always assume that it is a model with a high-voltage system until it can be proven otherwise using the identification features outlined in this ERG. External badging will usually be the first clue but it can often be hidden by damage caused in a crash. Always be sure to inspect multiple sides of the vehicle as well as using the clues found under the hood and in the interior of the vehicle.



Immobilize

The next step is to immobilize the vehicle to prevent any accidental movement that can endanger the emergency response personnel and any crash victims. Since the IONIQ Plug-in Hybrid has the ability to shut down the gasoline engine when it is not needed, there will be instances where the vehicle appears to be off because of the absence of engine noise. When in its “ready” mode, the vehicle can move almost silently using the electric motor alone. Responders should approach the vehicle from the sides and stay away from the front or rear as they are both potential paths of travel. Instructions for immobilizing the vehicle are shown below.



Chock the Wheels



Engage Parking Brake

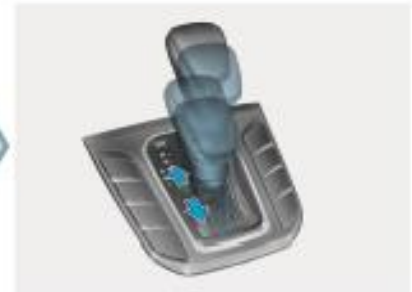

Position the shift lever in park (P)

Disable

The final step in the initial response process, conducted after the vehicle is secured to prevent movement, is to disable the vehicle, its SRS components and the high voltage electrical system. To prevent current flow through the system, use one of the following procedures to disable the vehicle.

Disabling the system – Smart Key System and “POWER” START/STOP BUTTON

1. Check the status of the READY light on the instrument panel. If the READY light is illuminated, the vehicle is on.

(Refer to page 6)

a) If the READY light is NOT illuminated, the vehicle is off, Do not push the “POWER” START/STOP button because the vehicle may restart.

b) To turn off the system, put the shift lever in the P (Park) position and press the POWER button beside a shift lever.

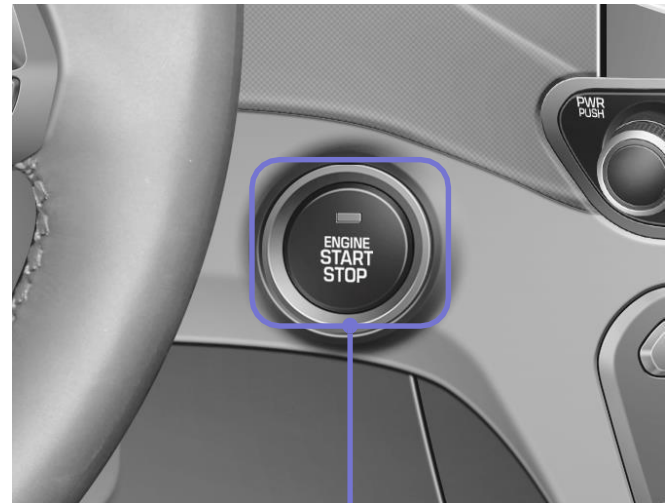

“POWER” START/STOP Button

Without depressing the brake pedal

Pressing POWER button	Button Position	Vehicle condition
	OFF	Off
One time	ACC	Electrical accessories are operational.
Two times	ON	The warning lights can be checked before the vehicle is started.
Three times	OFF	Off

Depressing the brake pedal while a shift lever is in the P (Park) position

Pressing POWER button	Button Position	Vehicle condition
	OFF	Off
One time	-	Ready to drive

2. Before disconnecting the 12V battery, move the smart key at least 2 meters away from the vehicle to prevent accidental restart.



Smart Key

3. Disconnect the negative (-) 12V battery cable (B), located in the boot, to further prevent the risk of accidental restart.

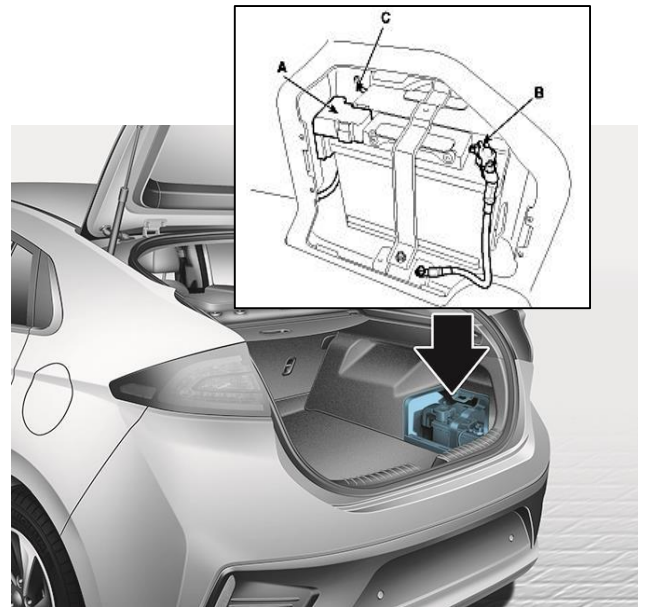

NOTICE

If necessary, lower the windows, unlock the doors and open the boot as required, before disconnecting the 12V battery. Once the 12V battery is disconnected, power controls will not operate.

4. Use the following procedure to remove the safety plug and disable the high voltage battery:

a) Remove the safety plug cover (A) located under the right side of the boot luggage cover.



b) Remove the safety plug using the following procedure : A: Unlock → B: Release → C: Remove

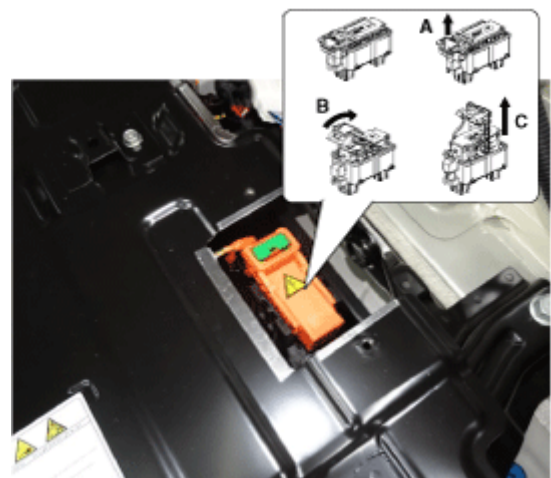

II . Disabling the system – IG Relay Removal (Alternate Method)

1. Open the bonnet.
2. Remove the motor compartment fuse box cover.

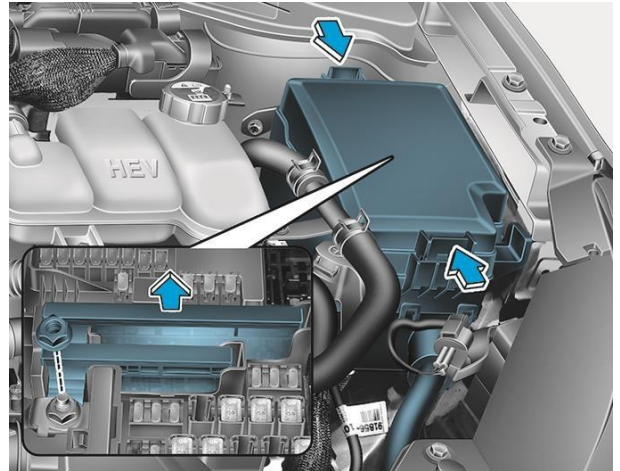

3. In the event the vehicle cannot be disabled using the “Power” START/STOP Button, pull the IG1, IG2 fuses or relays from the engine compartment room fuse box. If the IG fuses cannot be located, pull out all the fuses and relays in the fuse box.

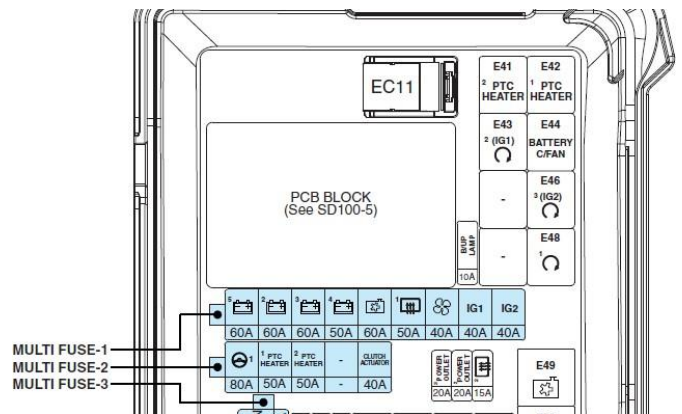

Engine Compartment Fuse Box

4. Disconnect the negative (-) 12V battery cable (B), located in the boot, to further prevent the risk of accidental restart.

NOTICE

If necessary, lower the windows, unlock the doors and open the boot as required, before disconnecting the 12V battery. Once the 12V battery is disconnected, power controls will not operate.

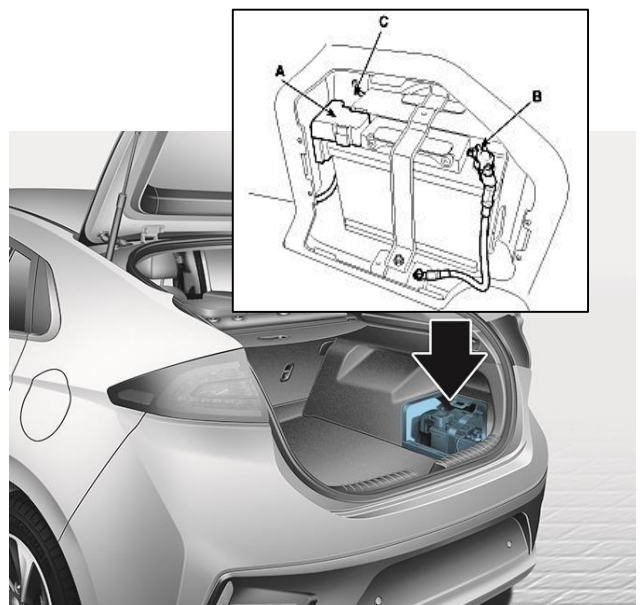

5. Use the following procedure to remove the safety plug and disable the high voltage battery:

a) Remove the safety plug cover (A) located under the right side of the boot luggage cover.

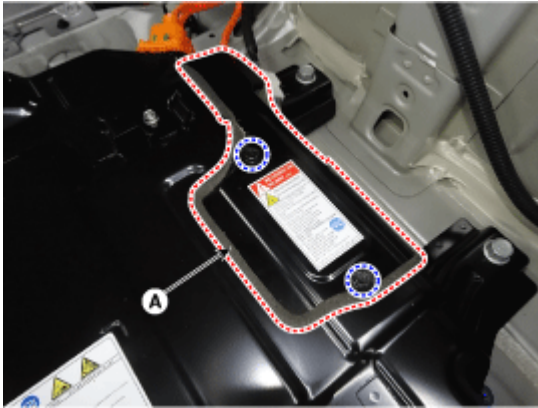

b) Remove the safety plug using the following procedure : A: Unlock → B: Release → C: Remove

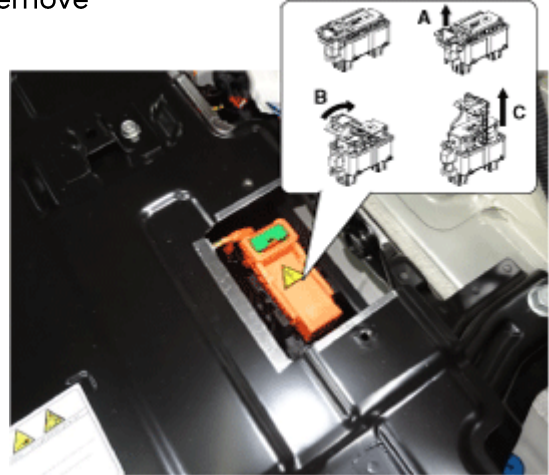

If both methods of disabling system are unsuccessful, the vehicle is not secured from accidental deployment of airbags and electric shock from high-voltage components.

WARNING Electrocutation Risk

- Before engaging in emergency response procedures, ensure the vehicle is disabled and wait for more than 5 minutes to allow the capacitor in the high voltage system to discharge to avoid electrocution.
- Exposed cables or wires may be visible inside or outside the vehicle. To prevent injury or death due to electrical shock, never touch the wires or cables before disabling the system, to prevent injury or death due to electrical shock.

Failure to follow any of these instructions may result in serious injury or death by electrocution.

WARNING Electrocutation Risk

- Do not cut through any component.
- SRS components may remain powered and active for up to 3 minutes after the 12V electrical system is shut off or disabled. Disconnect the battery negative cable and wait for at least 3 minutes before beginning work.

Failure to follow any of these instructions may result in serious injury or death from accidental deployment of the airbag system.

Extrication Operations

The extrication operations for the IONIQ Plug-in Hybrid are similar to the conventional vehicle. However, the first responder should pay special attention when they extract occupants in the vehicle. Before extrication operations, the first responders should carry out “Initial Response: Identify, Immobilize and Disable” procedure section of this manual.

Vehicle Stabilization

Use standard stabilization (cribbing) points, as shown. Always be sure to connect to a structural member of the vehicle and avoid placing cribbing under high voltage cables, fuel lines and other areas not normally considered acceptable.

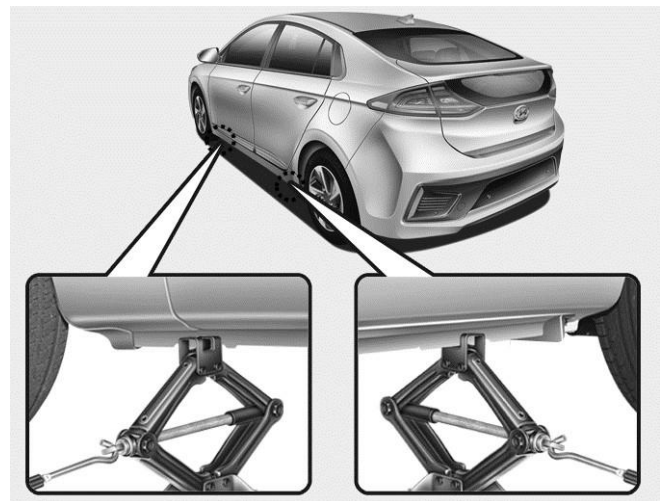

Extrication Tools & Procedure

When responding to an incident involving a IONIQ Plug-in Hybrid, we recommend that the first responders follow their organization's standard operating procedures for assessing and dealing with vehicle emergencies. When the first responders cut the vehicle, they should always pay special attention to airbag system, orange coloured high voltage cables and other high voltage components to avoid damage to parts which may increase the risks of explosion.

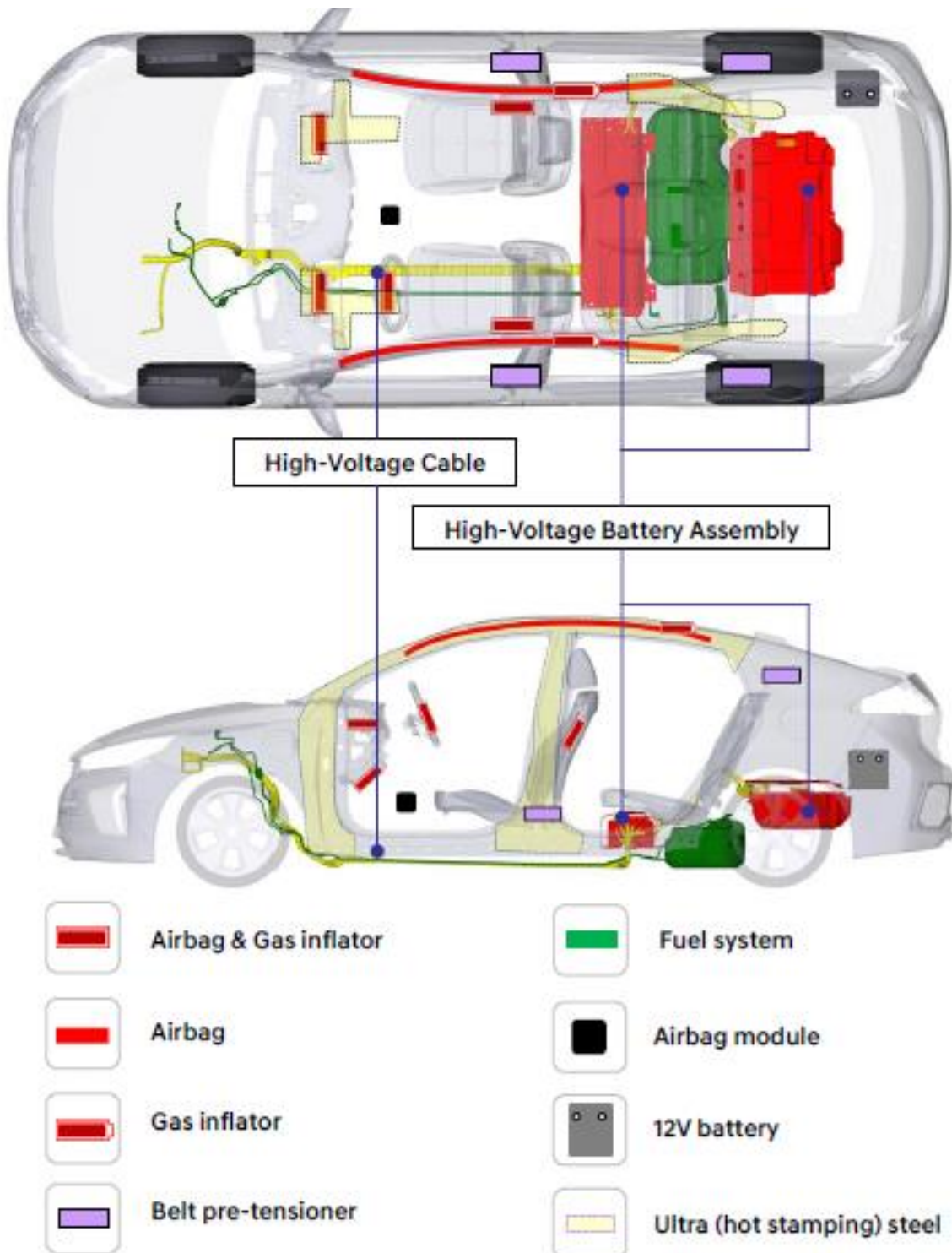

Submersion

Some emergency responses can involve a submerged vehicle. A IONIQ Plug-in Hybrid that is submerged does not have high-voltage component on the vehicle's body or framework. It is safe to touch the vehicle's body or framework if there is no severe damage to the vehicle, whether it is in water or on land. In the event the vehicle is submerged or partially submerged, remove the vehicle from the water before attempting to disable the vehicle. Drain the water from the vehicle. Use one of the methods described in sections of this manual.

WARNING

- If severe damage causes high-voltage components to become exposed, responders should take appropriate precautions and wear appropriate insulated personal protective equipment.
- Do not attempt to remove a safety plug while in the water.

Failure to follow any of these instructions may result in serious injury or death by electrocution.

Vehicle Fire

After Initial Emergency Response Procedures have been applied, Firefighting Procedures may begin. Hyundai recommends that each response team follow their own department's standard operating procedures for fighting vehicle fires in combination with the IONIQ Plug-in Hybrid specific details that are covered in this section.

Firefighting Operations

If the high-voltage battery pack is either involved in or at risk of being involved in a fire in a IONIQ Plug-in Hybrid, strict cautions must be taken while conducting firefighting operations due to following reasons:

- Lithium-ion Polymer batteries contain gel electrolyte that can vent, ignite, and produce sparks when subjected to temperatures above 150°C.
- May burn rapidly with a flare-burning effect.
- Even after the high-voltage battery fire appears to have been extinguished, renewed or delayed fire can occur.
- Use a thermal imaging camera to ensure the high voltage battery is completely cooled before leaving the incident.
- Always advise second responders that there is a risk of the battery re-igniting.
- Fire, submersion or a collision that has compromised the high voltage battery, always store it in an open area with no exposures within 15 metres.
- A burning battery could release hydrogen fluoride, carbon monoxide, and carbon dioxide gasses. Use NIOSH/MSHA approved full-face self-contained breathing apparatus (SCBA) with full protective gear. Even if the high-voltage battery pack is not directly involved in a vehicle fire, approach the vehicle very carefully.

Extinguishers

- Small fires that high voltage battery is not involved : Extinguish fires using a ABC extinguisher for an electric fire.
- Fires that the high voltage battery is involved or the high voltage battery is heating : Extinguish fires using large and sustained amount of water to cool the high voltage battery. Do not extinguish fire with a small amount of water. Firefighters should not hesitate to pour large amounts of water on the vehicle.

High-Voltage Battery Damage and Fluid Leaks

The HV Battery assembly is enclosed in a sturdy metal case that is rigidly mounted to structural components of the vehicle. This construction helps prevent damage to the HV Battery assembly even in severe crashes. This section provides emergency responders with information regarding how to mitigate the severity of a damaged HV Battery assembly or gel electrolyte spill, however unlikely that might be.

- Cease all smoke, spark, flame activity around the vehicle.
- Electrolyte solution is a skin irritant.
- Do not touch or step on the spilled electrolyte.
- If electrolyte leak occurs, wear appropriate solvent resistant PPE and use oil, sand, or a dry cloth to clean up the spilled electrolyte. Be sure to adequately ventilate the area.

WARNING Irritant Substance Risk!

- Internal components of HV Batteries are irritants and sensitizers.
- To avoid contact with these irritants and sensitizers wear positive pressure self-contained breathing apparatus (SCBA) and other personal protective equipment (PPE) designed for use with these types of hazards. Failure to wear proper SCBA and PPE can result in serious injury or death.

- Electrolyte solution is an eye irritant – If contact with eyes, rinse with plenty of water for 15 minutes.
- Electrolyte solution is a skin irritant. Therefore, if there is contact with skin, wash off with soap.
- Electrolyte liquid or fumes that have come into contact with water vapours in the air will create an oxidized substance. This substance may irritate skin and eyes. In these cases, rinse with plenty of water and see a doctor immediately.
- Electrolyte fumes (when inhaled) can cause respiratory irritation and acute intoxication Move to a well ventilated location for fresh air and wash mouth with water. See a doctor immediately.

Towing

When towing IONIQ Plug-in Hybrid vehicle, all wheels should be off the ground and not in contact with the road. If emergency towing is necessary, we recommend having it done by an authorized Hyundai dealer or a commercial tow-truck service. The use of wheel dollies or flatbed is recommended.

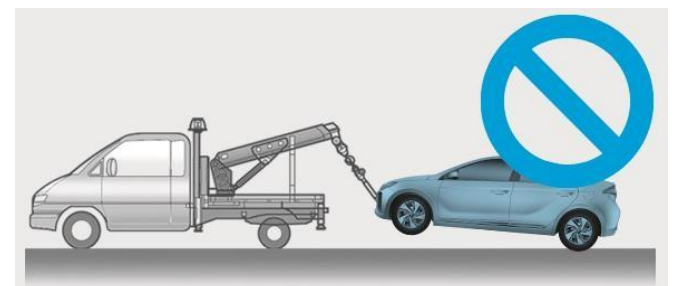
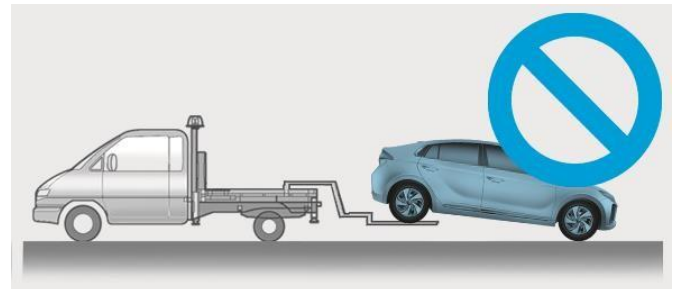
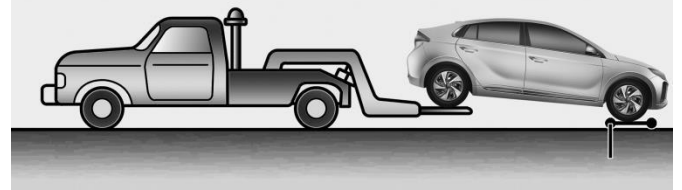
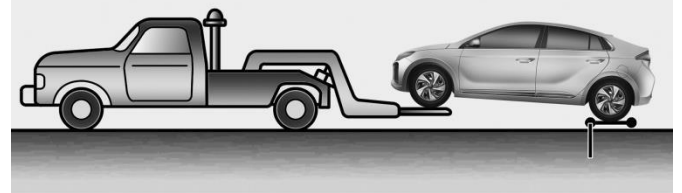
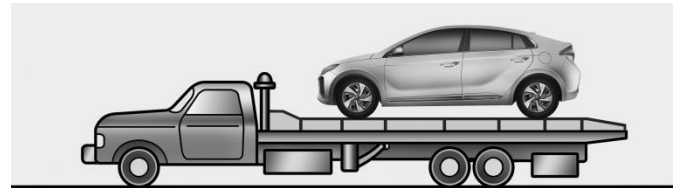

⚠ CAUTION

- Do not tow the vehicle backwards with the front wheels on the ground as this may cause damage to the vehicle.
- Do not tow with sling-type equipment. Use wheel lift or flatbed equipment.
- Never tow the vehicle with the front wheels on the ground (forward or backward), as this may cause damage to the vehicle.

To Jump Start the Car

1. Make sure the booster battery is 12-volt.
2. If the booster battery is in another vehicle, do not allow the vehicles to touch.
3. Turn off all unnecessary electrical loads.
4. First connect one end of a jumper cable to the positive terminal of the discharged battery in the motor compartment, then connect the other end to the positive terminal on the booster battery.

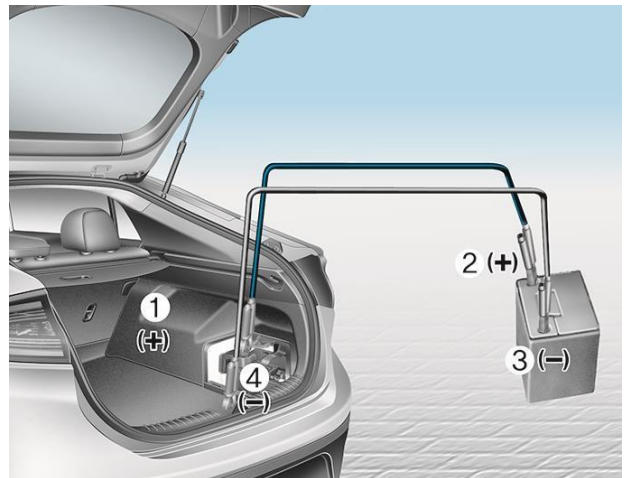

Proceed to connect one end of the other jumper cable to the negative terminal of the booster battery, then the other end to a solid, stationary, metallic point away from the battery (for example, the boot lid latch).

CAUTION

- Do not connect the cables to or near any part that moves when the vehicle is started.
- Do not allow the jumper cables to contact anything except the correct battery terminals or the correct ground.
- Do not lean over the battery when making connections.

5. Start the vehicle with the booster battery, then start the vehicle with the discharged battery.
6. After a few minutes, turn off both of the vehicles.
7. Remove the negative terminal cable first, and then remove the positive terminal cable. If the cause of your battery discharging is not apparent, we recommend that the system be checked by an authorized HYUNDAI dealer.

HYUNDAI HELP LINE
0800 HYUNDAI (498 632)